

TEFC Motor Silencer

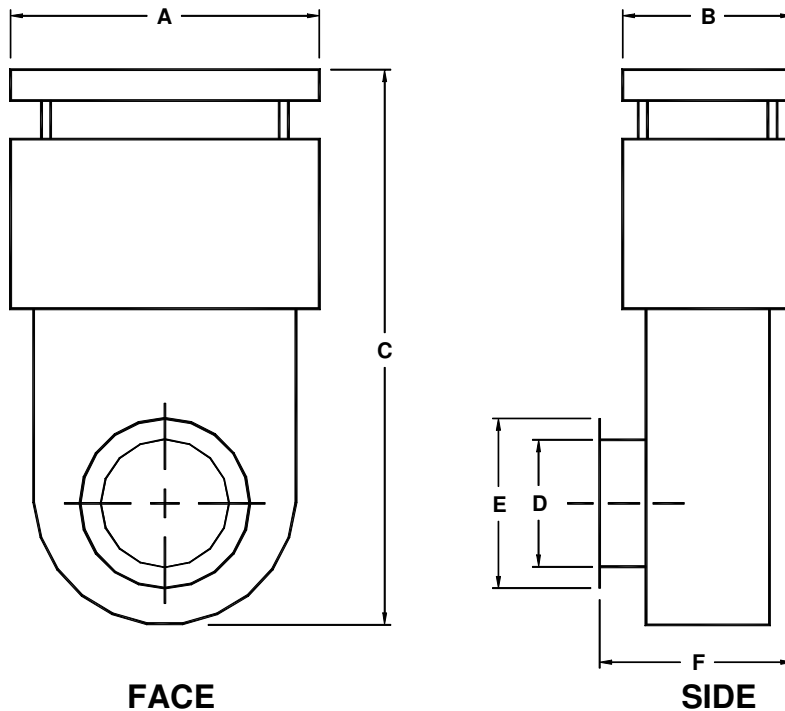

*This information is necessary if holes are to be pre-punched. If these specifications are not furnished, mounting flanges must be drilled on the job by installer.

Silencer construction is Aluminum. Adapter fitting is steel. Both have powder coat finish.

Each unit is complete with two Oxel® square attenuating spirals, mounting gasket, adapter fitting, and inlet screen.

We will identify silencers by area, fan, or motor number only if it's requested.

MODEL NUMBER

Dim	VA 77-2S	VA 88-2S	VA 99-2S	VA 1010-2S	VA 1212-2S	VA 1414-2S	VA 1420-2S	VA 1624-2S	VA 1826-2S	
A	20"	22"	24"	26"	30"	34"	34"	38"	42"	
B	11"	12"	13"	14"	16"	18"	18"	20"	22"	
C	36"	38"	40"	42"	44"	52"	58"	64"	72"	
INLET SIZE (USER SPECIFIED)	D									
O.D. OF FLANGE (USER SPECIFIED)	E									
	F	12½"	13½"	14½"	15½"	17½"	19½"	19½"	24½"	28"
*SIZE OF BOLT CIRCLE										
NUMBER & SIZE OF MOUNTING BOLTS										
*LOCATION OF 1 ST BOLT (0 DEG AT 3 O'CLOCK, ETC.)										





ATTENUATION AND AIR FLOW

Model number	INSERTION LOSS AT 3FT.							AIR FLOW CFM		APPROX. WT. IN LBS.	
	B.B. dBA	125 dB	250 dB	500 dB	1000 dB	2000 dB	4000 dB	@ 0.50"	@ 0.75"	SILENCER	ADAPTER
VA 77-2S	45	31	30	28	37	48	63	1420	1650	34	12
VA 88-2S	44	35	33	45	42	46	63	2600	2900	42	14
VA 99-2S	43	29	29	45	42	47	63	2900	3350	49	16
VA 1010-2S	46	29	32	39	45	51	63	4900	5600	54	18
VA 1212-2S	46	29	38	37	43	53	63	6500	7400	68	20
VA 1414-2S	46	28	35	34	36	49	63	7900	8200	85	24
VA 1420-2S	47	28	32	41	39	47	63	9400	10300	91	24
VA 1624-2S	52	31	34	38	47	49	62	12000	13800	126	50
VA 1826-2S	44	28	29	34	36	46	62	15000	16100	176	80

Above reading were taken during in-plant tests of Silencers. Air flow and pressure drop tests follow the joint Standard **ASHRAE 51-75** and **AMCA 210-74**. Attenuation tests made in large reverberant room, reading high level noise at selected frequencies, "open speaker", and "attenuator in place", using **GENRAD 1565-A** And **1933** meters, calibrated with **1562-A** calibrator before test. Broad band noise generated by **GENRAD type 1390-A** noise source.

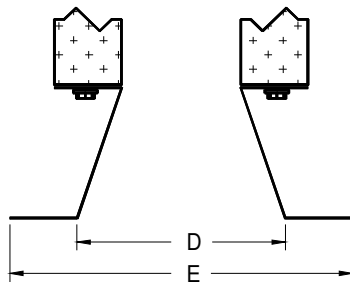

TYPE 1 ADAPTER

TAPER CONNECTS SILENCER TO LARGER SIZE INLET ON MOTOR

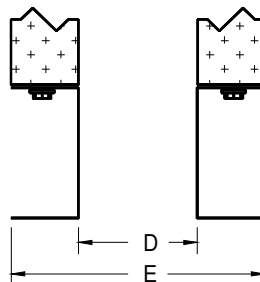

TYPE 2 ADAPTER

ADAPTER IS STRAIGHT – NO TAPER

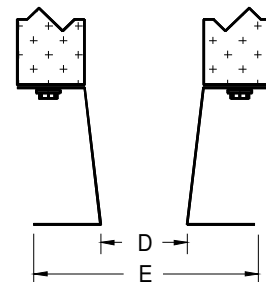

TYPE 3 ADAPTER

ADAPS LAGER SIZE SILENCER TO SMALLER AIR INLET ON MOTOR

NOTE: Special adapters can be furnished for your requirements if you will supply a sketch. Adapters have internal acoustical treatment. Adapter types 1, 2, and 3 will be punched to match the mounting flange of your equipment if you specify numbers and size of bolt holes and diameter of bolt circle. In ordering vertical silencers, VA series, specify location of first bolt, i.e. 0 degrees (3 o'clock) etc.





SELECTION GUIDE FOR TEFC MOTOR SILENCERS

Selection and sizing of the correct silencer for any particular TEFC motor is simple; the primary elements to be considered are:

1. Air flow (CFM) requirements
2. Motor air inlet diameter
3. Motor HP
4. Space restrictions around the motor
5. Noise levels at inlet, exhaust, and frame

The chart below will help you in the selection of the correct VA Series silencer for your particular motor. If you have any questions, our technical staff will work with you to confirm the correct size for your specific application.

Airflow (CFM) @ 0.50" W.G.	Airflow (CFM) @ 0.75" W.G.	Motor Inlet Size	Motor HP	Silencer Model
1,420	1,650	up to 12"	15-30	VA 77-2S
2,600	2,900	up to 14"	25-75	VA 88-2S
2,900	3,350	up to 16"	40-75	VA 99-2S
4,900	5,600	up to 18"	75-100	VA 1010-2S
6,500	7,400	up to 21"	100-250	VA 1212-2S
7,900	8,200	up to 24"	125-300	VA 1414-2S
9,400	10,300	up to 24"	125-450	VA 1420-2S
12,000	13,800	up to 30"	500-800	VA 1624-2S
15,000	16,100	up to 36"	800 +	VA 1826-2S

Simple Installation

There are two methods of installation:

1. Use of an acoustically treated adapter fitting.
2. Direct mounting with required air inlet opening and bolt holes built into the silencer base.

Either type of installation may be offset to one side to avoid moving electrical controls, conduits or structural supports.

